

MARK	DATE	REVISION	REVISER	APP .BY
①				
②				
③				

MODEL NO		QAP100H		
MATERIAL		HOUSING-ABS		
		RESONANCE CHAMBER-ABS		
		-		
COLOR OF HOUSING		MAKER STANDARD		
USE VOLT.	CURRNET	DC12V ~ 24V	MAX. 0.800A	
		AC110V ~ 220V	MAX. 0.175A	
KIND OF SOUND	VOLUME	WARNING SOUNDS 30Ch	MAX. 115dB at 1m	
		MP3 SOUNDS	MAX. 100dB at 1m	
PROTECTION GRADE		WATER & DUST PROOF - IP65		
CABLE ENTRY		φ10 CABLE ENTRY		

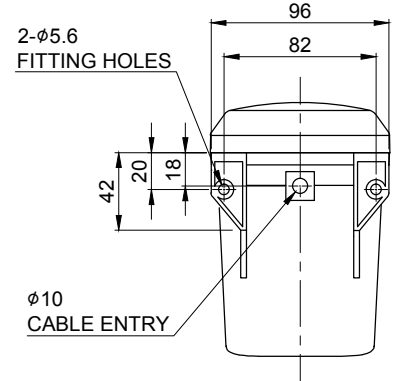
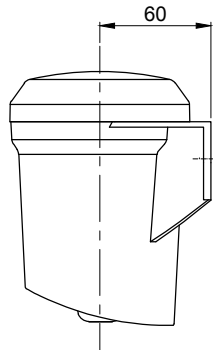
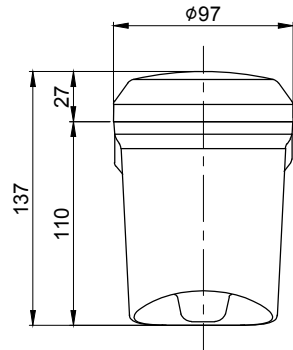

	ISO2768-1 : CLASS OF TOLERANCE					SURFACE FINISH
	f	m	Ⓢ	v		
FOR LINEAR DIMENSIONS	0.5~3	±0.05	±0.1	±0.2	-	
	3~6			±0.3	±0.5	
	6~30	±0.1	±0.2	±0.5	±1	
	30~120	±0.15	±0.3	±0.8	±1.5	
	120~400	±0.2	±0.5	±1.2	±2.5	
	400~1000	±0.3	±0.8	±2	±4	
FOR ANGULAR DIMENSIONS	0~10	±1°		±1°30'	±3°	
	10~50	±0°30'		±1°	±2°	
	50~120	±0°20'		±0°30'	±1°	
	120~400	±0°10'		±0°13'	±0°30'	

Nr.	DWG. NO.	TITLE/ NAME		MAT'L	QTY	REFERENCE
DSND BY	CHKD BY	CHKD BY	APRV BY	VIEW	DATE	
S.H.KIM	J.H.PARK		J.K.HAN	3	2019.03.20	
TITLE			MODEL			
QAP100H OUTLINE DRAWING			QAP100H			
			DWG. NO.		QAP100H_OUT	
			SCALE	SIZE	REV	SHEET
N/S	A4	00	1/1			