

Modular Multi-Functional LED Tower Lights

QT70(M)L series

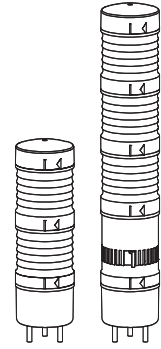

Thank you for purchasing Qlight's products. Please read this user manual carefully prior to installation and operation to ensure safe and correct use.

⚠ Precautions for Safety

Failure to follow the instructions below may cause a loss of life or serious physical injury.

1. During wiring or maintenance, please completely turn off the power of the product. (Failure to follow this may lead to an electric shock.)
2. Do not install the product in locations that subjects it to excessive dust or water other than the conditions designated by the IP protection ratings indicated for each product. (Failure to follow these instructions may cause a fire to the product, electric shock, physical injury, malfunction or damage to the product.)
3. Do not alter or repair this product. If maintenance or repair service is required, please contact your local Qlight contact point. (Failure to follow these instructions may lead to fire, electric shock, or product damage.)
4. Please apply the correct voltage to the product. (Failure to follow these instructions may lead to fire, electric shock, or product damage.)
5. When the product is applied to a condition that may impact lives or property, please make sure to have a double safety device. (Failure to follow this may cause damage to property, fire, electric shock and loss of life.)

⚠ Precautions for Correct Use

Failure to follow the proper instructions may cause damage to property, the product, or malfunction of the product that would void the warranty.

1. Please remove any objects that can interrupt ventilation around the product.
2. Please turn off the power of the product immediately if it fails to operate properly.
3. Carefully wire the product according to each product's specification.
4. Please be careful in preventing chemicals such as thinner, benzene, etc. in contact with the surface of the product.
5. Do not apply excessive force/impact to the product.
6. Failure to follow any of the instructions above may cause malfunction or damage to the product, fire, and electric shock.

Ordering Specifications

• QT70L

QT70L	3	24	RAG	QZ24
[Model number]	[Layer]	[Voltage]	[Color]	[Mounting option]
• QT70L	• Layer1-1	• 12-DC12V	R-Red	• (Blank)
• QT70LF	• Layer2-2	• 24-DC24V	A-Amber	- Standard type
• QT70ML	• Layer3-3	• 110-AC110V	G-Green	• Mounting type
• QT70MLF	• Layer4-4	• 220-AC220V	B-Blue	- LB24 - LW24
	• Layer5-5		W-White	- QZ24 - SZ24
				- QL24 - SL24

• QT70L-BZ

QT70L-BZ	3	24	RAG	QZ24
[Model number]	[Layer]	[Voltage]	[Color]	[Mounting option]
• QT70L-BZ	• Layer1-1	• 12-DC12V	R-Red	• (Blank)
• QT70LF-BZ	• Layer2-2	• 24-DC24V	A-Amber	- Standard type
• QT70ML-BZ	• Layer3-3	• 110-AC110V	G-Green	• Mounting type
• QT70MLF-BZ	• Layer4-4	• 220-AC220V	B-Blue	- LB24 - LW24
				- QZ24 - SZ24
				- QL24 - SL24

• QT70L-W

QT70L-W	3	24	RAG	QZ24
[Model number]	[Layer]	[Voltage]	[Color]	[Mounting option]
• QT70L-WS	• Layer1-1	• 12-DC12V	R-Red	• (Blank)
• QT70L-WM	• Layer2-2	• 24-DC24V	A-Amber	- Standard type
• QT70L-WA	• Layer3-3		G-Green	• Mounting type
• QT70LF-WS	• Layer4-4		B-Blue	- LB24 - LW24
• QT70LF-WM				- QZ24 - SZ24
• QT70LF-WA				- QL24 - SL24
• QT70ML-WS				
• QT70ML-WM				
• QT70ML-WA				
• QT70MLF-WS				
• QT70MLF-WM				
• QT70MLF-WA				



Please scan the QR code for more detailed product information.

www.qlight.com

Product Specifications

• QT70L

Model number	Layer	Voltage	Current	Certificate	Weight	Color
QT70L QT70LF	1	DC12V DC24V AC110V AC220V	0.100A 0.050A 0.020A 0.020A	CE	0.41kg 0.41kg 0.42kg 0.42kg	R-Red
	2	DC12V DC24V AC110V AC220V	0.200A 0.100A 0.040A 0.040A		0.48kg 0.48kg 0.49kg 0.49kg	R-Red G-Green
	3	DC12V DC24V AC110V AC220V	0.300A 0.150A 0.060A 0.060A		0.55kg 0.55kg 0.56kg 0.56kg	R-Red A-Amber G-Green
	4	DC12V DC24V AC110V AC220V	0.400A 0.200A 0.080A 0.080A		0.63kg 0.63kg 0.64kg 0.64kg	R-Red A-Amber G-Green B-Blue
	5	DC12V DC24V AC110V AC220V	0.500A 0.250A 0.100A 0.100A		0.71kg 0.71kg 0.72kg 0.72kg	R-Red A-Amber G-Green B-Blue W-White

• QT70ML

Model number	Layer	Voltage	Current	Certificate	Weight	Color
QT70ML QT70MLF	1	DC12V DC24V AC110V AC220V	0.100A 0.050A 0.020A 0.020A	CE	0.17kg 0.17kg 0.18kg 0.18kg	R-Red
	2	DC12V DC24V AC110V AC220V	0.200A 0.100A 0.040A 0.040A		0.25kg 0.25kg 0.26kg 0.26kg	R-Red G-Green
	3	DC12V DC24V AC110V AC220V	0.300A 0.150A 0.060A 0.060A		0.32kg 0.32kg 0.33kg 0.33kg	R-Red A-Amber G-Green
	4	DC12V DC24V AC110V AC220V	0.400A 0.200A 0.080A 0.080A		0.40kg 0.40kg 0.41kg 0.41kg	R-Red A-Amber G-Green B-Blue
	5	DC12V DC24V AC110V AC220V	0.500A 0.250A 0.100A 0.100A		0.47kg 0.47kg 0.48kg 0.48kg	R-Red A-Amber G-Green B-Blue W-White

• QT70L-BZ

Model number	Layer	Voltage	Current	Certificate	Weight	Color
QT70L-BZ QT70LF-BZ (Max. 90dB)	1	DC12V DC24V AC110V AC220V	0.115A 0.080A 0.110A 0.110A	CE	0.50kg 0.50kg 0.51kg 0.51kg	R-Red
	2	DC12V DC24V AC110V AC220V	0.215A 0.130A 0.130A 0.130A		0.58kg 0.58kg 0.59kg 0.59kg	R-Red G-Green
	3	DC12V DC24V AC110V AC220V	0.315A 0.180A 0.150A 0.150A		0.65kg 0.65kg 0.66kg 0.66kg	R-Red A-Amber G-Green
	4	DC12V DC24V AC110V AC220V	0.415A 0.230A 0.170A 0.170A		0.73kg 0.73kg 0.74kg 0.74kg	R-Red A-Amber G-Green B-Blue

• QT70ML-BZ

Model number	Layer	Voltage	Current	Certificate	Weight	Color
QT70ML-BZ QT70MLF-BZ (Max. 90dB)	1	DC12V DC24V AC110V AC220V	0.115A 0.080A 0.110A 0.110A	CE	0.26kg 0.26kg 0.27kg 0.27kg	R-Red
	2	DC12V DC24V AC110V AC220V	0.215A 0.130A 0.130A 0.130A		0.34kg 0.34kg 0.35kg 0.35kg	R-Red G-Green
	3	DC12V DC24V AC110V AC220V	0.315A 0.180A 0.150A 0.150A		0.42kg 0.42kg 0.43kg 0.43kg	R-Red A-Amber G-Green
	4	DC12V DC24V AC110V AC220V	0.415A 0.230A 0.170A 0.170A		0.49kg 0.49kg 0.50kg 0.50kg	R-Red A-Amber G-Green B-Blue

• QT70L-W

Model number	Layer	Sound pattern and volume	Voltage	Current	Certificate	Weight	Color
QT70L-WS QT70L-WM QT70L-WA QT70LF-WS QT70LF-WM QT70LF-WA	1	WS-5 Warning Sounds WM-5 Melodies WA-5 Alarms (Max,85dB)	DC12V	0.320A	CE	0.62kg	R-Red
			DC24V	0.180A			R-Red
	2		DC12V	0.420A		0.69kg	R-Red
			DC24V	0.230A			G-Green
	3		DC12V	0.520A		0.76kg	R-Red
			DC24V	0.280A			A-Amber G-Green
	4		DC12V	0.620A		0.84kg	R-Red
			DC24V	0.330A			A-Amber G-Green B-Blue

• QT70ML-W

Model number	Layer	Sound pattern and volume	Voltage	Current	Certificate	Weight	Color
QT70ML-WS QT70ML-WM QT70ML-WA QT70MLF-WS QT70MLF-WM QT70MLF-WA	1	WS-5 Warning Sounds WM-5 Melodies WA-5 Alarms (Max,85dB)	DC12V	0.320A	CE	0.37kg	R-Red
			DC24V	0.180A			R-Red
	2		DC12V	0.420A		0.44kg	R-Red
			DC24V	0.230A			G-Green
	3		DC12V	0.520A		0.54kg	R-Red
			DC24V	0.280A			A-Amber G-Green
	4		DC12V	0.620A		0.59kg	R-Red
			DC24V	0.330A			A-Amber G-Green B-Blue

※ CE compliant : DC24V

• Protection rating :

IP65(QT70L, QT70ML)
IP54(QT70L-BZ, QT70ML-BZ,
QT70L-W, QT70ML-W)

• Ambient operating temperature:

-30°C to +50°C

QT70L

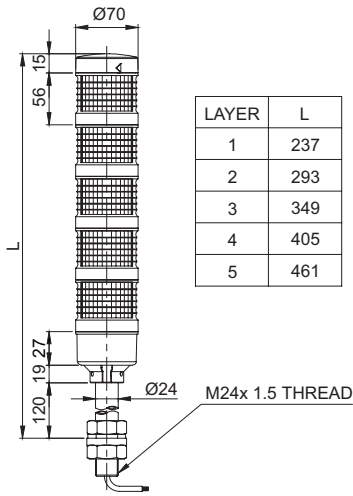

QT70L-BZ

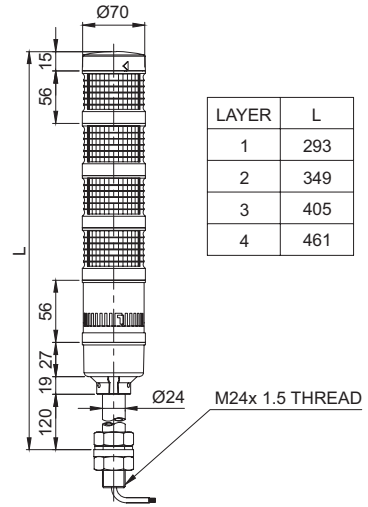

QT70L-W

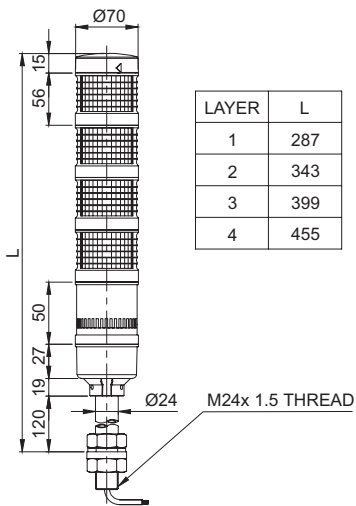

QT70ML

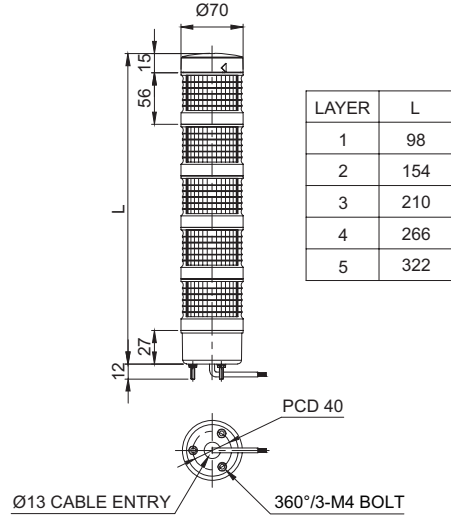

QT70ML-BZ

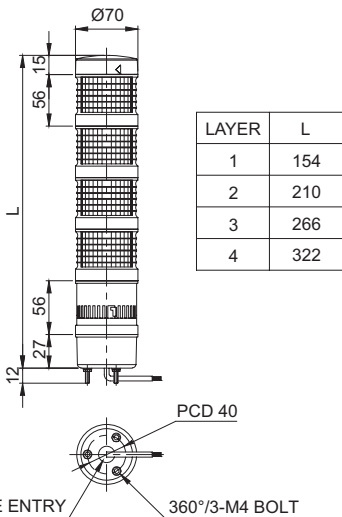

QT70ML-W

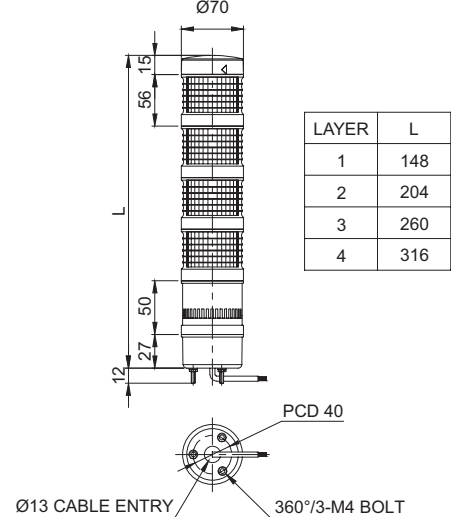

Wiring Instructions

■ Wiring using external contact

• In case of wiring with external contacts, refer to the wiring diagrams below according to your product's type and voltage setting.

	Wiring instructions		Wiring instructions
DC/AC standard		DC/AC built-in sounder	
QT70ML QT70MLF QT70MLS QT70MLR QT70L QT70LF		QT70ML QT70MLF QT70MLS QT70MLR QT70L QT70LF	<ul style="list-style-type: none"> • QT70(M)L-Including WS/WM/WA type • QT70(M)LF-Including WS/WA type
DC/AC buzzer		DC/AC built-in sounder internal switch	
QT70ML-BZ QT70MLFL-BZ QT70MLSL-BZ QT70MLRL-BZ QT70LL-BZ QT70LFL-BZ		QT70ML QT70MLF QT70MLS QT70MLR QT70L QT70LF	<ul style="list-style-type: none"> • QT70(M)L-Including WS/WM/WA type • QT70(M)LF-Including WS/WA type

• DC steady type cable specification : External power/ signal line - UL1007 AWG22(0.3sq) 400mm.

• AC steady, AC/DC steady/flashing type cable specification : External power line - UL1015 AWG18(0.75sq) × 2C 400mm,
External signal line - UL1007 AWG22(0.3sq) 400mm

■ Wiring using transistor

- When using a transistor, please choose between the NPN or PNP type transistor which best matches the voltage and product type, then connect them correctly according to the wiring diagrams below.

		Wiring instructions	
DC/AC standard		<p>NPN-Transistor External Transistor-NPN</p> <p>Layer 1 Layer 2 Layer 3 Layer 4 Layer 5</p> <p>Red Amber Green Blue White</p> <p>Black Fuse Power</p>	<p>PNP-Transistor External Transistor-PNP</p> <p>Layer 1 Layer 2 Layer 3 Layer 4 Layer 5</p> <p>Red Amber Green Blue White</p> <p>Black Fuse Power</p>
DC/AC buzzer		<p>NPN-Transistor External Transistor-NPN</p> <p>Layer 1 Layer 2 Layer 3 Layer 4</p> <p>Red Amber Green Blue Brown</p> <p>Black Fuse Power</p>	<p>PNP-Transistor External Transistor-PNP</p> <p>Layer 1 Layer 2 Layer 3 Layer 4</p> <p>Red Amber Green Blue Brown</p> <p>Black Fuse Power</p>
		Wiring instructions	
DC/AC built-in sounder		<p>NPN-Transistor External Transistor-NPN</p> <p>Ch 1 Ch 2 Ch 3 Ch 4 Ch 5</p> <p>Layer 1 Layer 2 Layer 3 Layer 4</p> <p>Gray/Red (GR/R) Gray/Amber (GR/A) Gray/Blue (GR/B) Gray/Green (GR/G) Gray/White (GR/W)</p> <p>Red Amber Green Blue Black White Black</p> <p>Common Flash</p> <p>Black Fuse Power</p>	<p>DC/AC built-in sounder internal switch</p> <p>NPN-Transistor External Transistor-NPN</p> <p>Layer 1 Layer 2 Layer 3 Layer 4</p> <p>Red Amber Green Blue Brown</p> <p>Black Fuse Power</p>
<p>QT70ML QT70MLF QT70MLS QT70MLR QT70L QT70LF</p>		<p>QT70ML QT70MLF QT70MLS QT70MLR QT70L QT70LF QT70LS QT70LR</p>	<p>• QT70(M)L-Including WS/WM/WA type • QT70(M)LF-Including WS/WA type</p> <p>• QT70(M)L-Including WS/WM/WA type • QT70(M)LF-Including WS/WA type</p>

- DC steady type cable specification : External power/ signal line - UL1007 AWG22(0.3sq) 400mm.
- AC steady, AC/DC steady/flashing type cable specification : External power line - UL1015 AWG18(0.75sq) × 2C 400mm, External signal line - UL1007 AWG22(0.3sq) 400mm

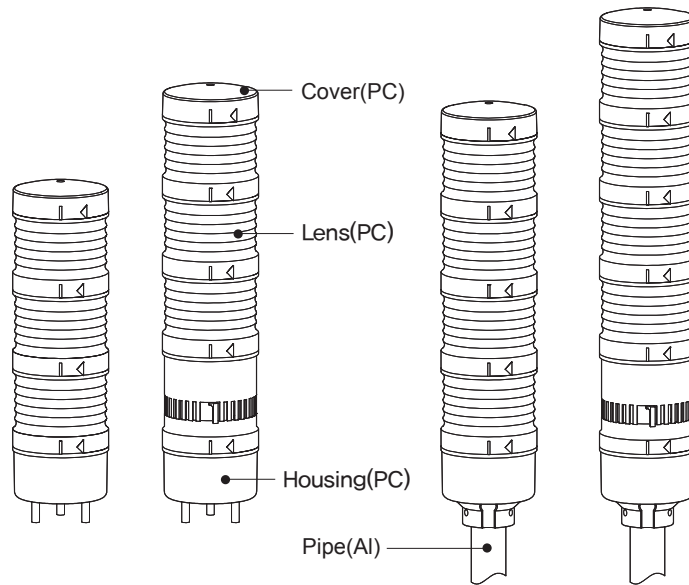

How to replace the module / Light Function Selection

How to replace the module

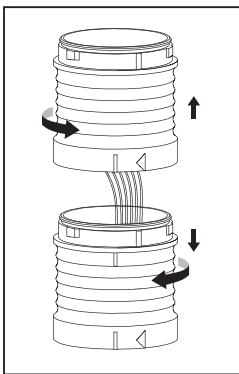

- Disassembling the module
- ① Twist the upper module kit in a counterclockwise direction so the "□" mark from both kits align.
- ② Disassemble by removing the upper module kit from the lower one.

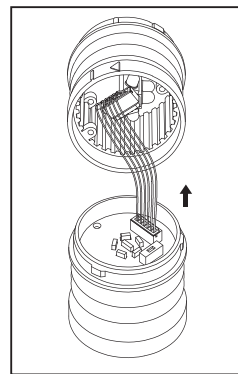

- How to disassemble the connector
- ① Disassemble the connector of the upper lens and the connector of the lower lens in the direction of the arrow.

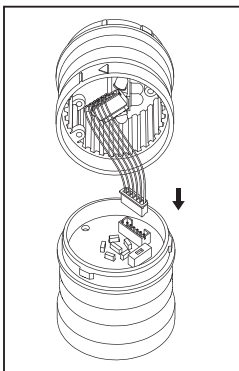

- How to assemble the connector
- ① Assemble the connector of the upper lens and the connector of the lower lens in the direction of the arrow.

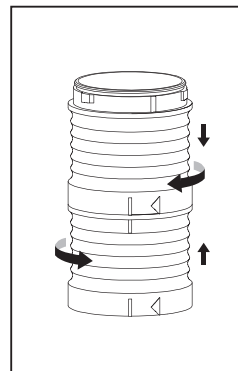

- Assembling the module
- ① Put the two module together by aligning the upper module' "□" mark and the lower module' "□" mark together.
- ② Lock the two kits by twisting the upper module kit in a clock wise direction so the upper module' "<" mark aligns with the lower module' "□" mark.

Light function selection

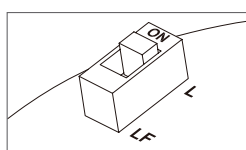
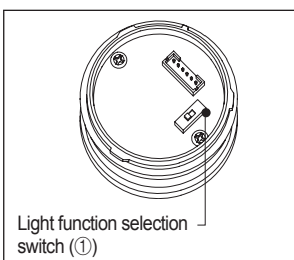

▶ L : Steady

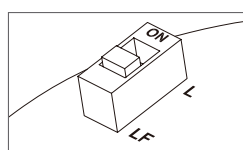

▶ LF : Flashing

- Please refer to the instruction below to use light function selection switch(①) located inside the product.
- Default function is set at steady LED. Select the desired function for your application during installation.

Buzzer Volume Adjustment Instructions

※ Built-in sounder type can't control the sound volume.

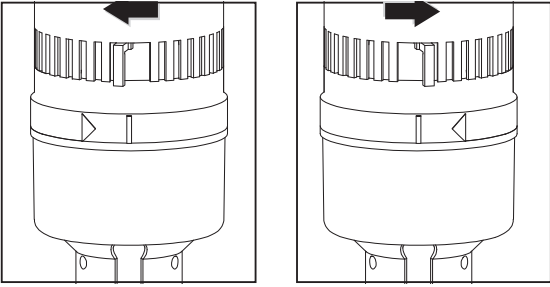

Buzzer volume is reduced by sliding the volume control lever to the left as show in the diagram.

(Min. 65±4dB/m)

Raise/ Increase the buzzer volume by sliding the control lever to the right as shown in the diagram.

(Max. 85±4dB/m)

Mounting Hole Specifications

① Machine holes on the mounting surface referring to the diagram below.

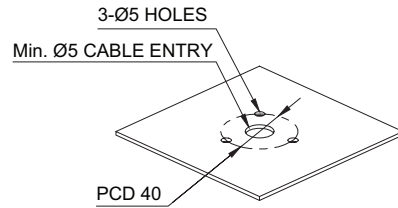

② Remove the flange nuts from bolts and place the product through the mounting surface holes.

③ Fasten the flange nuts on the opposite side of the mounting surface until the product is tightened securely.

Installation Environment and Protection Rating

- This product is designed for indoor use with protection rating of IP65(standard type) or IP54(buzzer type).
- If the product is installed in locations that subject it to excessive dust or water other than the designated IP protection rating indicated, it may cause malfunction or damage to the product.
- For further information, please visit our website (www.qlight.com).

Mounting Accessories (Sold Separately)

• Please refer to the dimensions below for installation of mounting brackets

■ QT70ML/ QT70MLF - Direct Mounting Type Model

	Dimensions	
QT70ML series	<p>TWS80</p>	<p>TWA80</p>

■ QT70L - Pole Mounting Type Model

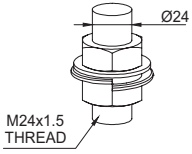
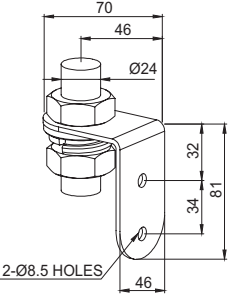
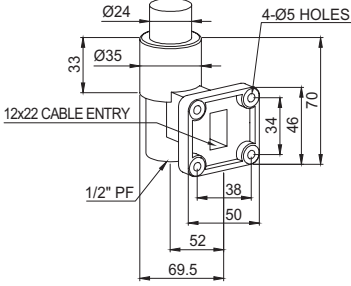
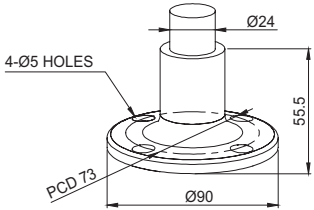
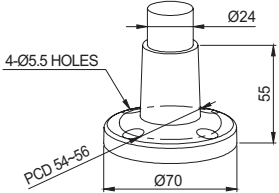
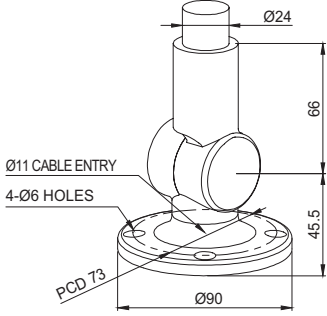
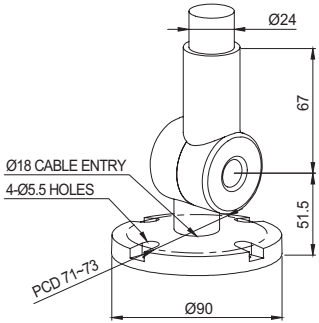
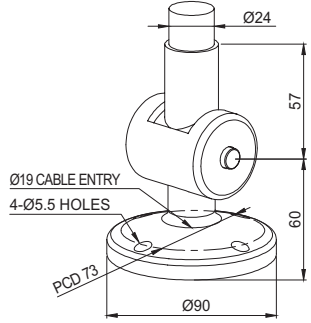
		Dimensions		
QT70L series	 <p>M24x1.5 THREAD</p> <p>Ø24</p>	 <p>70</p> <p>46</p> <p>Ø24</p> <p>32</p> <p>34</p> <p>81</p> <p>2-Ø8.5 HOLES</p> <p>46</p>	24mm SCREW & NUT	LB24
	 <p>Ø24</p> <p>4-Ø5 HOLES</p> <p>33</p> <p>Ø35</p> <p>12x22 CABLE ENTRY</p> <p>1/2" PF</p> <p>34</p> <p>46</p> <p>70</p> <p>38</p> <p>50</p> <p>52</p> <p>69.5</p>	 <p>Ø24</p> <p>4-Ø5 HOLES</p> <p>55.5</p> <p>PCD 73</p> <p>Ø90</p>	LW24	SZ24
	 <p>Ø24</p> <p>4-Ø5.5 HOLES</p> <p>55</p> <p>PCD 54-56</p> <p>Ø70</p>	 <p>Ø24</p> <p>4-Ø6 HOLES</p> <p>Ø11 CABLE ENTRY</p> <p>66</p> <p>45.5</p> <p>PCD 73</p> <p>Ø90</p>	QZ24	SL24
	 <p>Ø24</p> <p>Ø18 CABLE ENTRY</p> <p>4-Ø5.5 HOLES</p> <p>67</p> <p>51.5</p> <p>PCD 71-73</p> <p>Ø90</p>	 <p>Ø24</p> <p>Ø19 CABLE ENTRY</p> <p>4-Ø5.5 HOLES</p> <p>57</p> <p>60</p> <p>PCD 73</p> <p>Ø90</p>	QL24	QLA24

Technical Certification

- Qlight products are designed to meet strict quality and technical standards. Thus, the Qlight brand is widely recognized for its high quality and technical innovations from leading institutions around the world.



ISO International Organization for Standardization

Qlight quality assurance systems have been certified by ISO by applying the ISO 9001:2008, KS Q ISO 9001:2009 regulation.



IECEX International Explosion Proof Certification (IECEX)

Certified that Qlight's products are being manufactured and manage according to international standards.



ATEX The European Regulatory Framework or Manufacture, Installation and Use of Equipment in Explosive Atmospheres

Qlight's explosion proof products comply with ATEX Directives 94/9/EC.



NEPSI National Supervision and Inspection Center for Explosion Protection and Safety of Instrumentation

Qlight's design and manufacturing system meets the People's Republic of China National explosion proof Standard. (Chinese Standard-GB3836/GB12476)



KCs Explosion Proof Device Safety Certification System

The safety performance of machines and equipment subject to safety certification and Technical capability and production system have been certified safety certification standards.



TIIS Japan Explosion-proof Certification

TIIS is a Japanese explosion proof test and certification system accordance with the Ministry of Health, Labour and Welfare Notice and the explosion proof guidelines for factory electrical equipment. Qlight's explosion proof products have been tested and certified by TIIS.



ABS American Bureau of Shipping

Qlight's design and quality assurance system has been certified by the American Bureau of Shipping.



RMRS Russian Maritime Register of Shipping

Qlight's design and quality assurance system has been certified from Russian Maritime Register of Shipping.



CCS China Classification Society

Qlight's design and quality assurance system has been certified by the China Classification Society.



KR Korean Register of Shipping

Qlight's design and quality assurance system has been certified by the Korean Register of Shipping.



LR Lloyd's Register

Qlight's design and quality assurance system has been certified from Lloyd's Register.



E-mark Commission Directive Regarding Vehicle Industry

Qlight has obtained EU mark for approved vehicles and vehicle components sold into the EU (EEA : European Economic Area)



KC Korea Safety Certification

Qlight's products are certified by KC for preventing accident caused by fire.



KCC Conformity Assessment of Broadcasting Communication Equipment

Qlight has been certified to protect the electromagnetic environment that causes unwanted electromagnetic waves from the device, communication failure due to other devices or external radio waves, and malfunction of the device.



CCC China Compulsory Certificate

Qlight's has obtained CCC which guarantees safety, protection against fraud, environment, etc.



CCCF China Certification Center for Security & Protection

Qlight has passed the rigorous examination process of "Passing Fire Protection Products Centering" In order to sell fire-fighting products such as fire alarm equipment to Chinese market.



UL Underwriters Laboratories

Qlight's design and quality assurance system has been certified from UL to ensure the stability of consumption goods and to protect consumers.



CE European Commission

Qlight has been certified by the European Commission.



ICAO International Civil Aviation Organization

Qlight guarantees our products satisfy the criteria regulated by the International Civil Aviation Organization (ICAO, FAA).



RoHS2 Restriction of Hazardous Substances Directive

Qlight complies with the Restriction of Hazardous Substances Directive by limiting its use of hazardous materials.

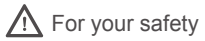

For your safety

Specification and dimensions listed in this catalogue subject to change without notice for product quality improvement.
The newest product information is available on our website.(www.qlight.com)
Please read the instruction manual attached to the product carefully before installation and use.

Qlight Co., Ltd. www.qlight.com | trade@qlight.com

Head Office | Suite #1510, STX-V Tower, 128 Gasan digital 1-ro, Geumcheon-gu, Seoul, Korea Tel. +82-80-328-2222 Fax : +82-2-2679-6154

Factory | 185-25, Mukbang-ro, Sangdong-myeon, Gimhae-si, Gyeongsangnamdo, Korea Tel. +82-80-328-1111

Qlight Overseas Sales Dept | 704 Nakdong-daero, Sasang-gu, Busan, Korea(Eomgung-Dong) Tel : +82-51-620-4100

Qlight Public Relations & Marketing Team Office | 704 Nakdong-daero, Sasang-gu, Busan, Korea(Eomgung-Dong) Tel : +82-51-245-0017

Qlight USA, Inc. www.qlight.com www.qlightusa.com | sales@qlightusa.com

3003 North First Street, Suite #341, San Jose, CA 95134 USA Tel. +1.408.519.5740 Fax. +1.408.519.5739

SHANGHAI Qlight Electronic Co., Ltd. www.qlight.com www.qlightcn.com | qlightcn@qlight.com

China Factory/ Shanghai Sales Office | #19, Nanda Road, Baoshan Area, Shanghai, China Tel. +86.21.6651.7100 Fax. +86.21.6315.3929

Qlight
Innovation in Alarm & Signal

Product Operation Inquiry / Customer Support +82-51-620-4100

You can expect prompt service if you have exact information such as model name, symptom, telephone number and address.

※ALL PRODUCT, PRODUCT SPECIFICATIONS AND DATA ARE SUBJECT TO CHANGE WITHOUT NOTICE TO IMPROVE RELIABILITY, FUNCTION OR DESIGN OR OTHERWISE.

Head office : Suite #1510, STX-V Tower, 128 Gasan digital 1-ro, Geumcheon-gu, Seoul, Korea (Postal Code : 08507)

Factory : 185-25, Mukbang-Ro, Sangdong-Myeon, Gimhae-Si, Gyeongsangnam-Do, Korea (Postal Code : 50805)

www.qlight.com